

3.0V, SOTiny™ 0.8Ω Dual SPDT Analog Switch with -1.0V to 4.2V Operating Range
Features

- Analog Signal Range: -1.0V to V_{CC} when switch is “ON”
- -1.0V Undershoot Protection when switch is “OFF”
- CMOS Technology for Bus and Analog Applications
- Low On-Resistance: 0.8Ω (+3.3V Supply)
- Wide V_{CC} Range: 1.5V to $4.2V \pm 10\%$
- Low Power Consumption : $5\mu W$
- Rail-to-Rail switching throughout Signal Range
- Fast Switching Speed: 50ns max. at 3.3V
- High Off Isolation: -50dB at 1 MHz
- -45dB (1 MHz) Crosstalk Rejection Reduces Signal Distortion
- Break-Before-Make Switching
- Extended Industrial Temperature Range: $-40^{\circ}C$ to $85^{\circ}C$
- Packaging: (Pb-free & Green)
 - 12-contact TDFN (ZE)
 - 12-contact TDFN (ZG)

Applications

- Cell Phones
- PDAs
- Portable Instrumentation
- Battery Powered Communications
- Computer Peripherals

Pin Description

Pin Number	Name ^(1,2,3)	Description
8, 11	NO _x	Data Port (Normally Open)
3, 6	GND _x	Ground
2, 5	NC _x	Data Port (Normally Closed)
1, 4	COM _x	Common Output/Data Port
9, 12	V_{CCx}	Positive Power Supply ⁽¹⁾
7, 10	IN _x	Logic Control

Notes:

1. X = 0 or 1
2. V_{CC0} and V_{CC1} are not internally connected. Each must be powered separately.
3. GND₀ and GND₁ are not internally connected. Each must be powered separately.

Description

The PI3A3160C is a high-bandwidth, fast Dual single-pole double-throw (SPDT) CMOS switch. It can be used as an analog switch or as a low-delay bus switch. Specified over a wide operating power supply voltage range, 1.5V to $4.2V \pm 10\%$, the switch has a typical On-Resistance of 0.8Ω at 3.3V.

Break-before-make switching prevents both switches from being enabled simultaneously. This eliminates signal disruption during switching.

Control inputs, IN, tolerates input drive signals up to 3.3V, independent of supply voltage.

PI3A3160C is a lower voltage and On-Resistance replacement for the PI5A3158.

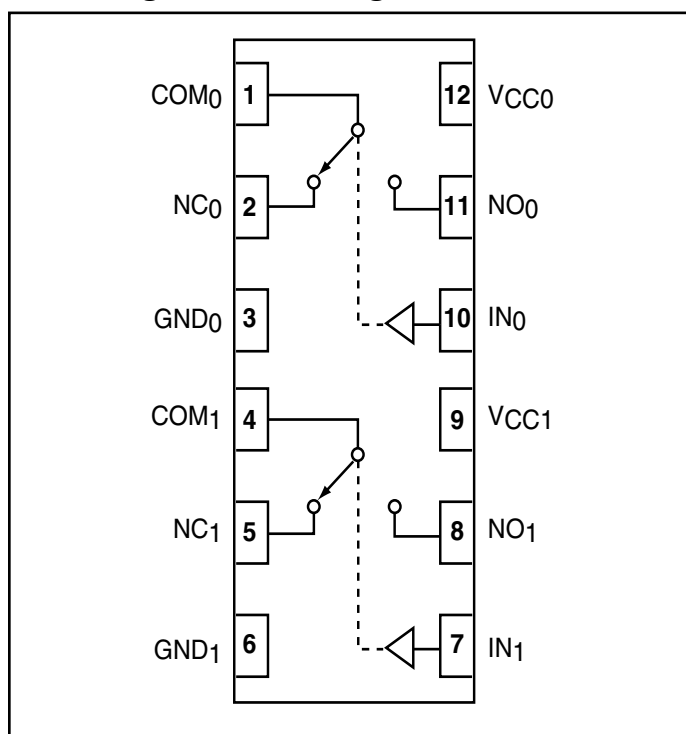
Block Diagram / Pin Configuration

Function Table

Logic Input	Function
0	NC _x Connected to COM _x
1	NO _x Connected to COM _x

Absolute Maximum Ratings

Voltages Referenced to GND

V _{CC}	-0.5V to 4.6V
V _{IN} , V _{COM} , V _{NC} , V _{NO} ⁽¹⁾	-1.5V to V _{CC} +0.3V or 30mA, whichever occurs first
Current (any terminal).....	±200mA
Peak Current, COM, NO, NC (Pulsed at 1ms, 10% duty cycle).....	±400mA
Temp Range	-40°C to + 85°C

Thermal Information

Continuous Power Dissipation	
TDFN-12 (derate 7.1mW/°C above +70°C).....	0.5W
Storage Temperature	-65°C to +150°C
Lead Temperature (soldering, 10s)	+300°C

Notes:

1. Signals on NC, NO, COM, or IN exceeding V_{CC} or GND are clamped by internal diodes. Limit forward diode current to 30mA.

Caution: Stresses beyond those listed under “Absolute Maximum Ratings” may cause permanent damage to the device. This is a stress only rating and operation of the device at these or any other conditions beyond those indicated in the operational sections of this specification is not implied.

Electrical Specifications - Single +3.3V Supply

(V_{CC} = +3.3V ± 10%, GND = 0V, V_{IH} = 1.4V, V_{IL} = 0.5V)

Parameter	Symbol	Conditions	Min. ⁽¹⁾	Typ. ⁽²⁾	Max. ⁽¹⁾	Units
Analog Switch						
Analog Signal Range ⁽³⁾	V _{ANALOG}		-1.0		V _{CC}	V
On-Resistance	R _{ON}	V _{CC} = 2.7V, I _{COM} = 100mA, V _{NO} or V _{NC} = +1.5V			1.3	Ω
On-Resistance Match Between Channels ⁽⁴⁾	ΔR _{ON}				0.15	
On-Resistance Flatness ⁽⁵⁾	R _{FLAT(ON)}	V _{CC} = 2.7V, I _{COM} = 100mA, V _{NO} or V _{NC} = 0.8V, 2.0V			0.1	
NO or NC Off Leakage Current ⁽⁶⁾	I _{NO(OFF)} or I _{NC(OFF)}	V _{CC} = 3.3V, V _{COM} = 0V, V _{NO} or V _{NC} = +2.0V	-2		2	μA
COM On Leakage Current ⁽⁶⁾	I _{COM(ON)}	V _{CC} = 3.3V, V _{COM} = +2.0V, V _{NO} or V _{NC} = +2.0V	-2		2	

Notes:

1. The algebraic convention, where most negative value is a minimum and most positive is a maximum, is used in this data sheet. T_A = 40°C to +85°C.
2. Typical values are for DESIGN AID ONLY, not guaranteed or subject to production testing. Typical values are tested w T_A = 25°C
3. Guaranteed by design.
4. ΔR_{ON} = R_{ON} max. - R_{ON} min.
5. Flatness is defined as the difference between the maximum and minimum value of On-Resistance measured.
6. Leakage parameters are 100% tested at maximum rated hot temperature and guaranteed by correlation at +25°C.

Electrical Specifications - Single +3.3V Supply (continued)

($V_{CC} = +3.3V \pm 10\%$, $GND = 0V$, $V_{IH} = 1.4V$, $V_{IL} = 0.5V$)

Parameter	Symbol	Conditions	Min. ⁽¹⁾	Typ. ⁽²⁾	Max. ⁽¹⁾	Units
Logic Input						
Input High Voltage	V_{IH}	Guaranteed Logic High Level	1.4			V
Input Low Voltage	V_{IL}	Guaranteed Logic LowLevel			0.5	
Input Current with Voltage High	I_{INH}	$V_{IN} = V_{CC}$, all others = 0V	-1		1	μA
Input Current with Voltage Low	I_{INL}	$V_{IN} = 0V$, all others = V_{CC}	-1		1	
Dynamic						
Turn-On-Time	t_{ON}	$V_{CC} = 3.3V$, V_{NO} or $V_{NC} = 2.0V$, Figure 1			50	ns
Turn-Off-Time	t_{OFF}				50	
Break-Before-Make	t_{BBM}	Figure 3	1		20	
Charge Injection ⁽³⁾	Q	$C_L = 1nF$, $V_{GEN} = 0V$, $R_{GEN} = 0\Omega$, Figure 2		110		pC
Off Isolation ⁽⁴⁾	O_{IRR}	$R_L = 50\Omega$, $f = 1$ MHz, Figure 4		-50		dB
CrossTalk ⁽⁵⁾	X_{TALK}	$R_L = 50\Omega$, $f = 1$ MHz, Figure 5				
NC or NO OffCapacitance	$C_{NC/NO}$ (OFF)	$f = 1$ MHz, Figure 6		35		pF
COM On Capacitance	$C_{COM(ON)}$	$f = 1$ MHz, Figure 7		110		
Control Input Capacitance	C_{IN}	$f = 1$ MHz		1		
-3dB Bandwidth	B_W	NO or NC to COM		65		MHz
Supply						
Power Supply Range	V_{CC}		1.5		4.6	V
Positive Supply Current	I_{CC}	$V_{CC} = 4.6V$, $V_{IN} = 0V$ or V_{CC}	210	280	350	μA

Notes:

- The algebraic convention, where most negative value is a minimum and most positive is a maximum, is used in this data sheet. $T_A = 40^\circ C$ to $+85^\circ C$.
- Typical values are for DESIGN AID ONLY, not guaranteed or subject to production testing. Typical values are tested w $T_A = 25^\circ C$
- Guaranteed by design..
- Off Isolation = $20\log_{10} [V_{COM} / (V_{NO} \text{ or } V_{NC})]$. See Figure 4.
- Between any two switches. See Figure 5.

Electrical Specifications - Single +2.5V Supply

($V_{CC} = +2.5V \pm 10\%$, $GND = 0V$, $V_{IH} = 1.4V$, $V_{IL} = 0.5V$)

Parameter	Symbol	Conditions	Min. ⁽¹⁾	Typ. ⁽²⁾	Max. ⁽¹⁾	Units
Analog Switch						
Analog Signal Range ⁽³⁾	V_{ANALOG}		-1		V_{CC}	V
On-Resistance	R_{ON}	$V_{CC} = 2.5V$, $I_{COM} = -8mA$, V_{NO} or $V_{NC} = 1.8V$		0.9		Ω
On-Resistance Match Between Channels ⁽⁴⁾	ΔR_{ON}	$V_{CC} = 2.5V$, $I_{COM} = -8mA$, V_{NO} or $V_{NC} = 0.8V, 1.8V$		0.1		
On-Resistance Flatness ⁽⁵⁾	$R_{FLAT(ON)}$			0.01		
Dynamic						
Turn-On-Time	t_{ON}	$V_{CC} = 2.5V$, V_{NO} or $V_{NC} = 1.8V$, Figure 1			50	ns
Turn-Off-Time	t_{OFF}					
Break-Before-Make	t_{BBM}	Figure 3	1		20	
Charge Injection ⁽³⁾	Q	$C_L = 1nF$, $V_{GEN} = 0V$, $R_{GEN} = 0V$, Figure 2		90		pC
Supply						
Positive Supply Current	I_{CC}	$V_{CC} = 2.75V$, $V_{IN} = 0V$ or V_{CC} All Channels on or off	120	160	200	μA
Logic Input						
Input High Voltage	V_{IH}	Guaranteed Logic High Level	1.4			V
Input Low Voltage	V_{IL}	Guaranteed Logic Low Level			0.5	
Input High Current	I_{INH}	$V_{IN} = V_{CC}$, all others = 0V	-1		1	μA
Input Low Current	I_{INL}	$V_{IN} = 0V$, all others = V_{CC}	-1		1	

Parameter	Symbol	Conditions	Min. ⁽¹⁾	Typ. ⁽²⁾	Max. ⁽¹⁾	Units
Positive Supply Current	I_{CC}	$V_{CC} = 1.5V$, $V_{IN} = 0V$ or V_{CC}	70	350	400	μA

Notes:

- The algebraic convention, where most negative value is a minimum and most positive is a maximum, is used in this data sheet.
 $T_A = 40^\circ C$ to $+85^\circ C$.
- Typical values are for DESIGN AID ONLY, not guaranteed or subject to production testing.
Typical values are tested w $T_A = 25^\circ C$
- Guaranteed by design.
- $\Delta R_{ON} = R_{ON} \text{ max.} - R_{ON} \text{ min.}$
- Flatness is defined as the difference between the maximum and minimum value of On-Resistance measured.

Test Circuits/Timing Diagrams

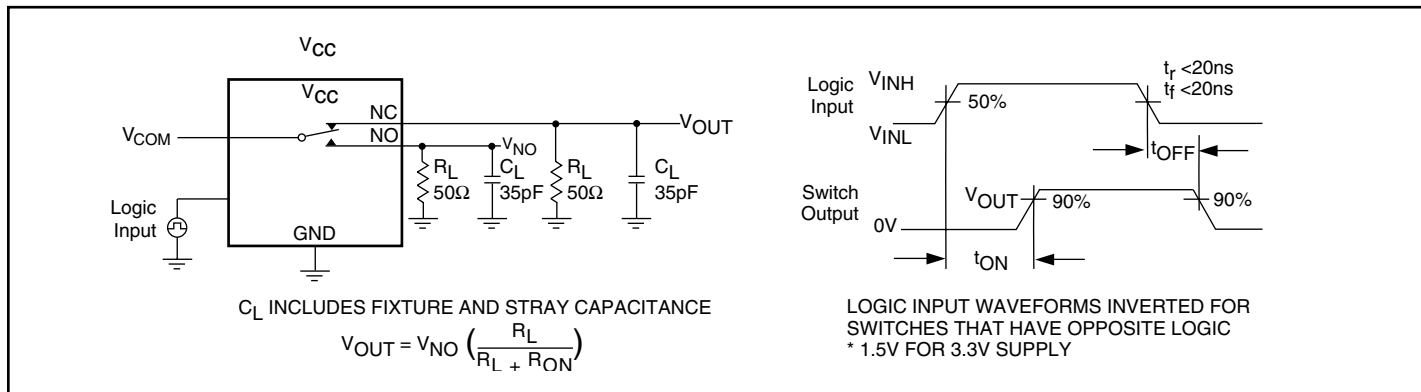

Figure 1. Switching Time

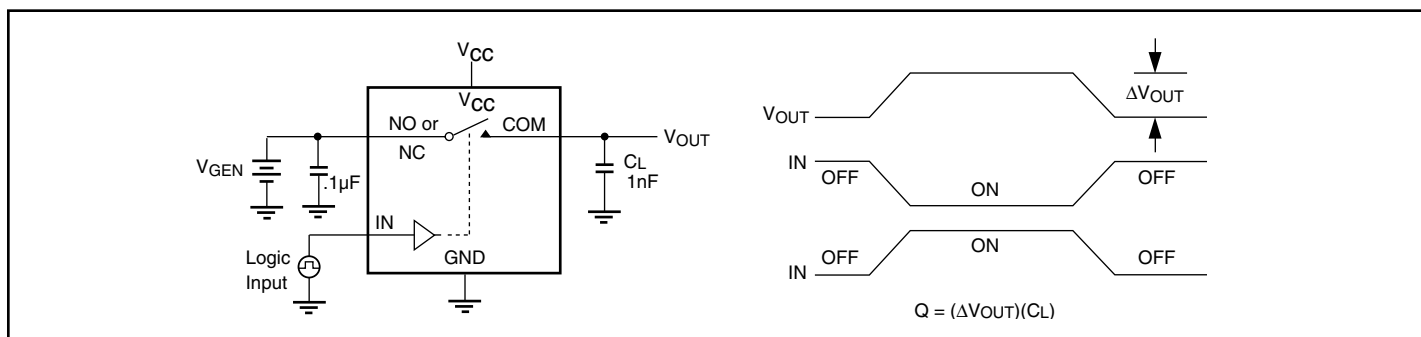

Figure 2. Charge Injection

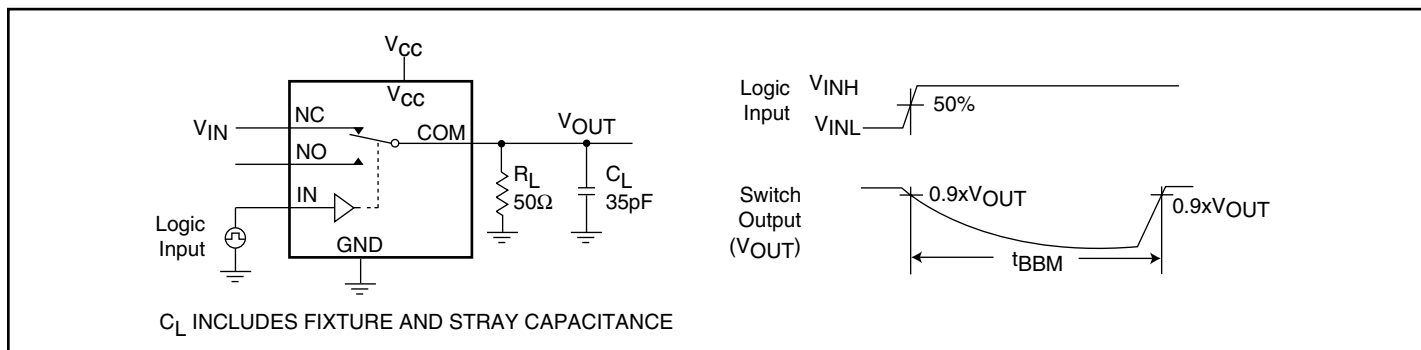

Figure 3. Break-Before-Make Interval

Test Circuits/Timing Diagrams (continued)

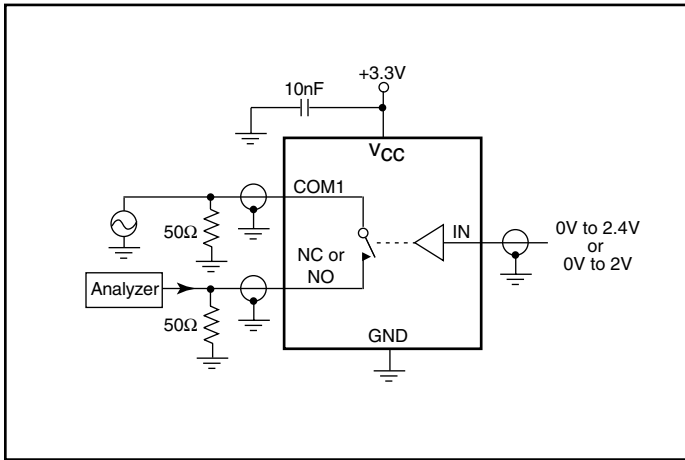

Figure 4. Off Isolation/On-Channel Bandwidth

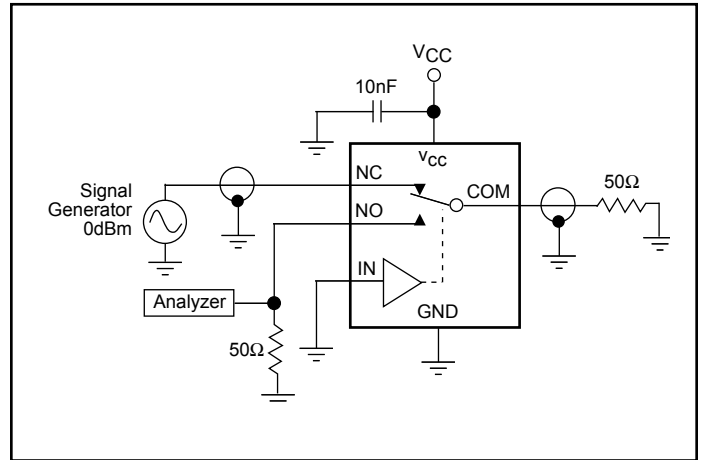

Figure 5. Crosstalk

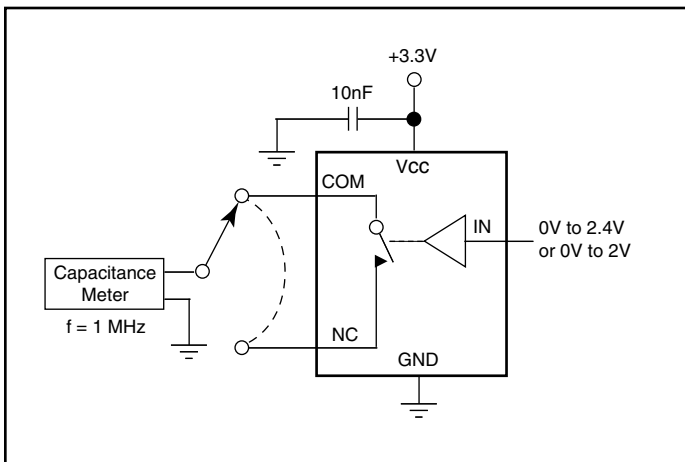

Figure 6. Channel-Off Capacitance

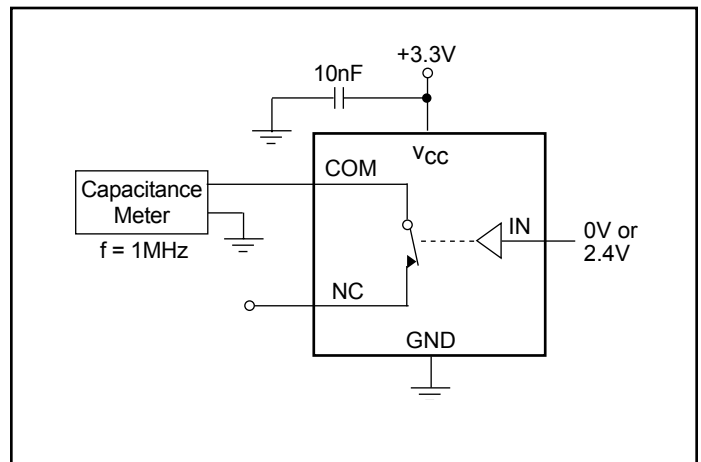

Figure 7. Channel-On Capacitance

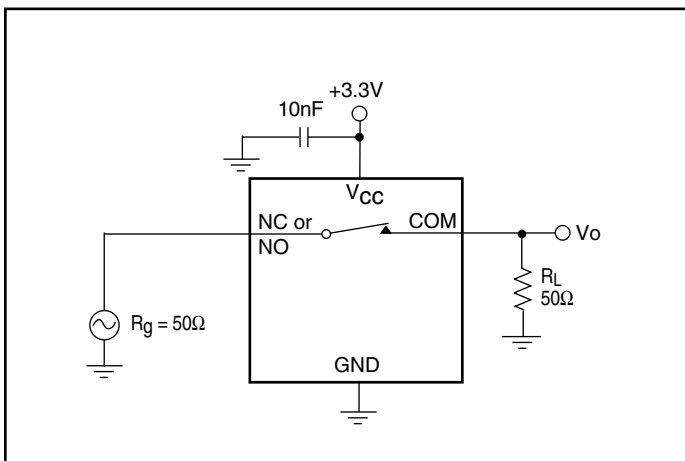
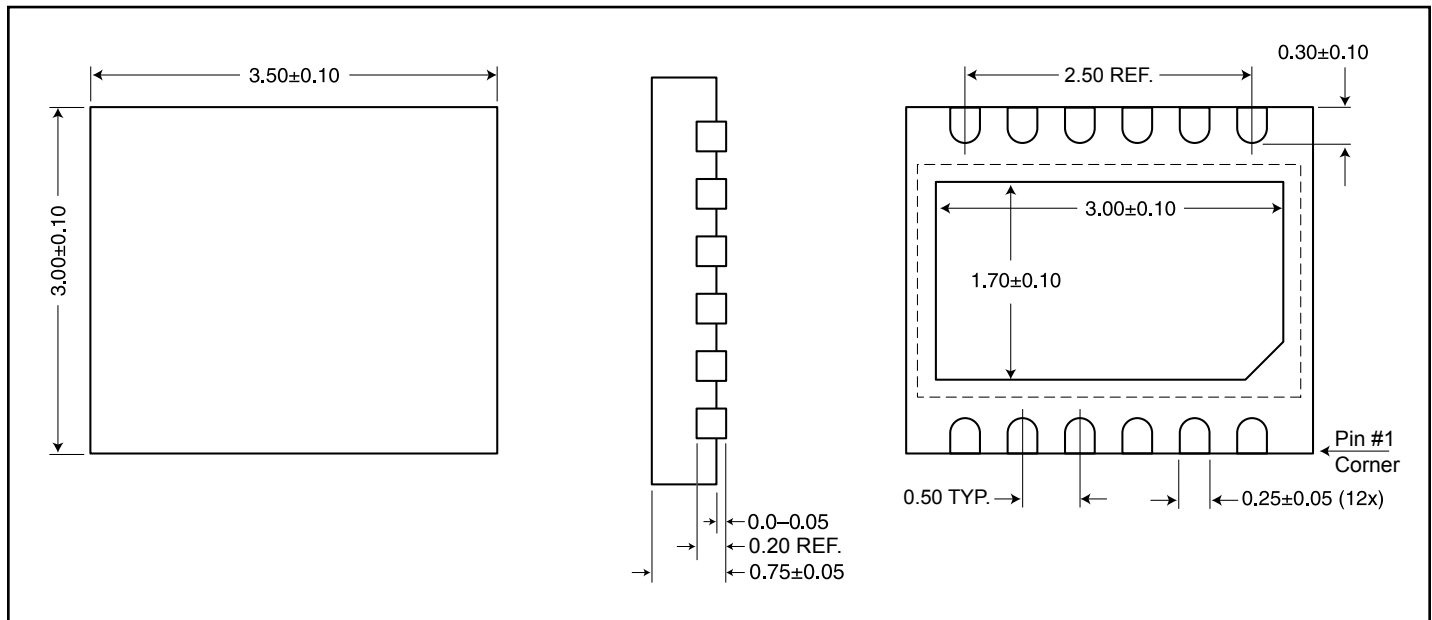
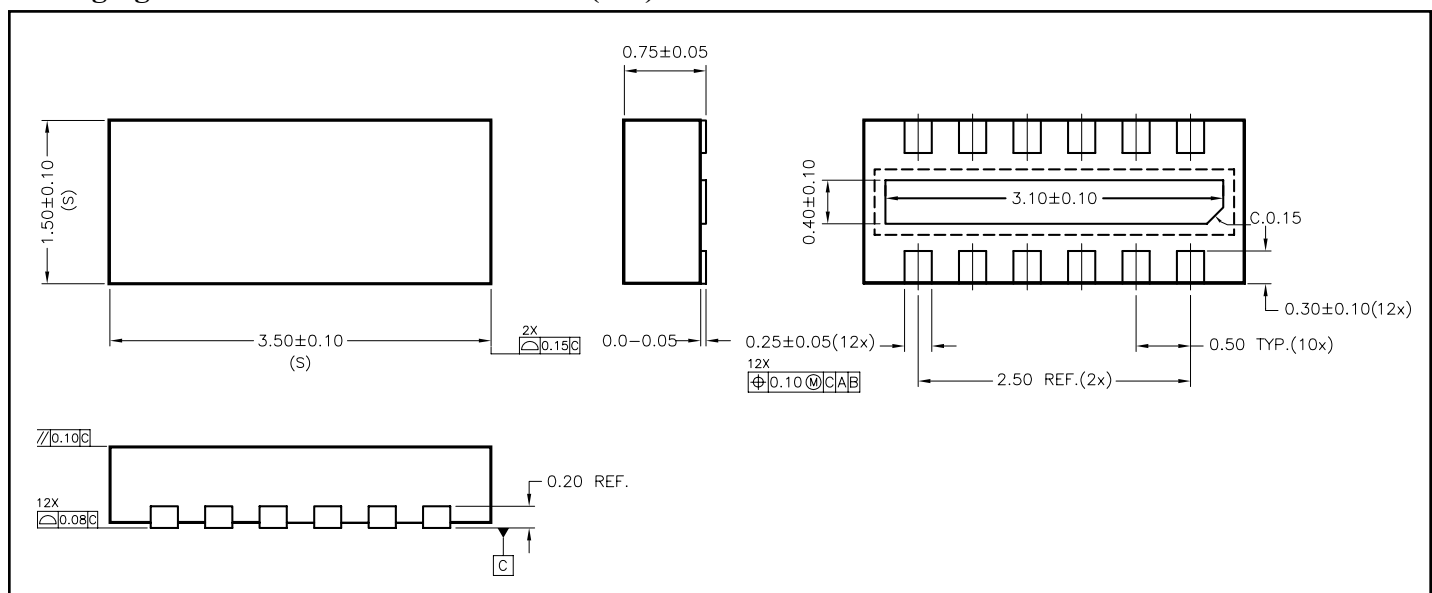

Figure 8. Bandwidth

Packaging Mechanical: 12-Contact TDFN (ZE)



Packaging Mechanical: 12-Contact TDFN (ZG)



Ordering Information

Ordering Code	Package Code	Package Type	Top Mark
PI3A3160CZEEX	ZE	Pb-free & Green, 12-contact TDFN	YH
PI3A3160CZGEX	ZG	Pb-free & Green, 12-contact TDFN	YH

Notes:

- Thermal characteristics can be found on the company web site at www.pericom.com/packaging/
- E = Pb-free and Green
- X suffix = Tape/Reel